

## OPV Series II Radio Unit Connection to RFL SMX3/40 Sub-MUX (X-21)

### Description

This application note covers the OPV Series II X-21 Synchronous Serial connection to the RFL SMX3/40 Sub-MUX.

Both transmit and receive data are timed to a single clock generated by the OPV Radio Units. The timing through the OPV system is synchronised end to end by having a slave as defined through CCMS, synchronise to a master.

When configured for X-21 the OPV Series II Radio Unit provides a 64 kbps data path, operating as a DCE and hence the Sub-MUX is required to operate as a DTE.

The provided 64 kHz system timing is typically  $\pm 5$  ppm or better while Jitter at the slave is  $\pm 0.1\%$ . Latency is better than 6 ms (typically 5.1 ms) while asymmetry is better than 125 us.

### Cable Wiring

The recommended cable is shielded twisted pair similar to Belden 1868E fitted with a shielded RJ-45 plug.

The following table outlines the required connections.

SMX3/40 (DTE)			OPV SII (DCE)		
Termination required	Signal	Pin – DB15 (female)	Pin – RJ45 (male)	Signal	In / Out
N/A	Tx Data A	2	2	Tx Data A	I
	Tx Data B	9	1	Tx Data B	
N	Timing A	6	6	Timing A	O
	Timing B	13	3	Timing B	
N	Rx Data A	4	5	Rx Data A	O
	Rx Data B	11	4	Rx Data B	
N/A	Not Used <sup>(1)</sup>	7	8	Not Used <sup>(1)</sup>	I
	Not Used <sup>(1)</sup>	14	7	Not Used <sup>(1)</sup>	
N/A	Shield / GND	Body	Body	Shield / GND	N/A
N/A	Signal GND	8	N/C	---	---

NOTE (1): These lines are not used and are wired for convenience only.

**Termination:** Although operation will not normally be prevented if the connecting cable is incorrectly terminated at the user equipment end, proper termination is strongly advised. As well as ensuring maximum signal integrity over longer cables, correct termination is necessary to ensure that compliance with CISPR22/EN55022 EMC standards is maintained.

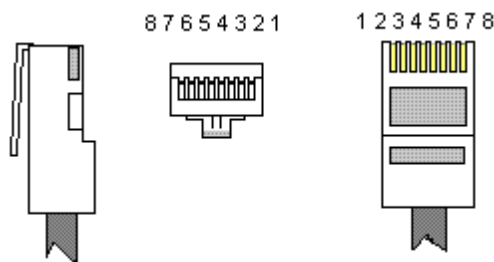
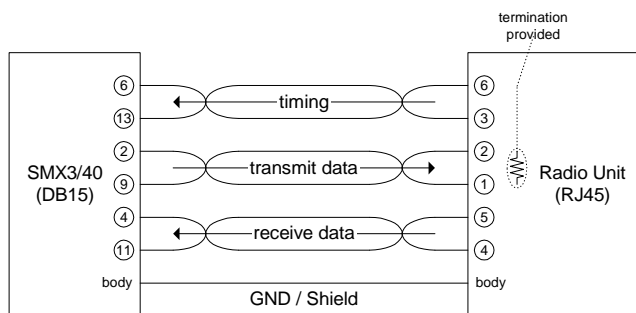

Shielded RJ-45 plug

**Grounding:** The Synchronous Serial drive circuitry is isolated from chassis ground (to 1500 VRMS) by means of opto-couplers and transformers. This is intended to prevent the possibility of ground loops. Therefore grounding of the shield at the SMX3/40 Sub-MUX (DTE) is required to prevent the shield and Synchronous Serial ground from floating.

### Radio Unit Configuration

Following are the CCMS settings required. NOTE: Only those relative to X-21 configuration are shown.

End A	
CCMS – Mode Select	X-21
CCMS – Clock Phase	Falling
CCMS – Establish link as	Master (a system control parameter)

End B	
CCMS – Mode Select	X-21
CCMS – Clock Phase	Falling
CCMS – Establish link as	Slave (a system control parameter)

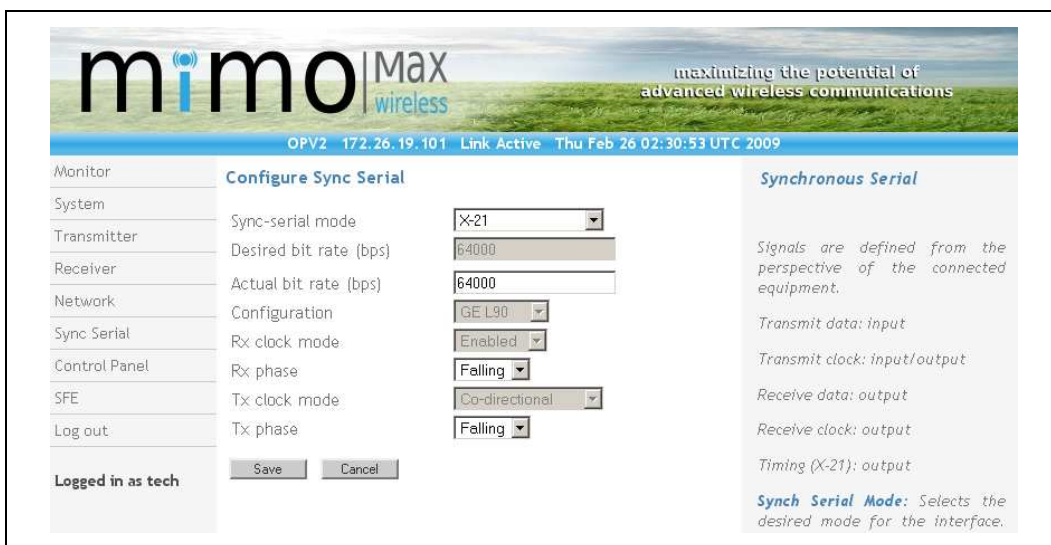

Radio Unit CCMS 'Synchronous Serial' page.  
Access is through the 'Sync Serial' tab.

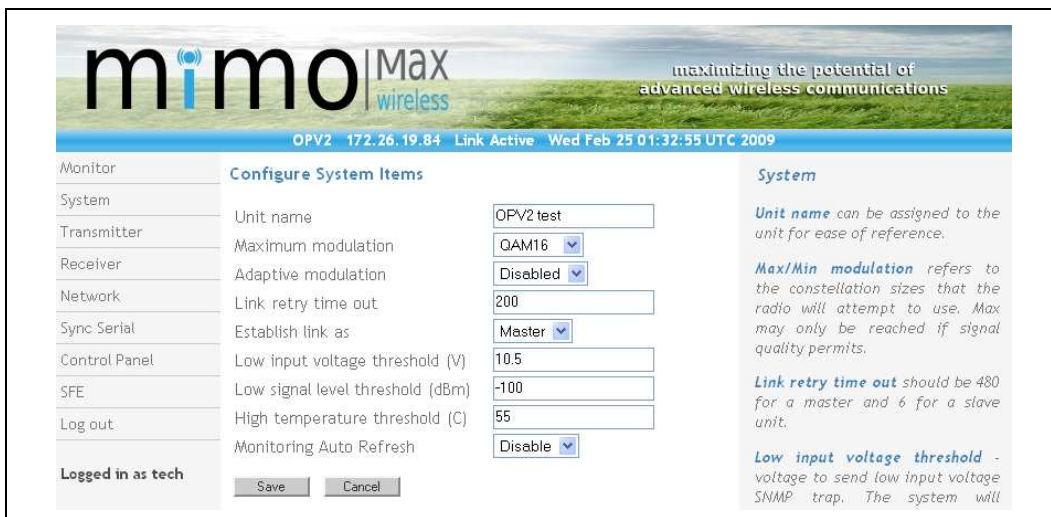

Radio Unit CCMS ‘Configure System Items’ page showing selection as a Master.  
 Access is through the ‘System / Configuration’ tab.

### SMX3/40 Sub-MUX Configuration

The following outlines the configuration applied to the SMX3/40 Sub-MUX during testing.

- Channel 0: Transparent, X21 Port, 2400 baud
- Channel 1: Async 8bit, X21 Port, 2400 baud
- Channel 2: Async 8bit, X21 Port, 2400 baud
- Channel 3: Disabled
- X21 Port: Enabled
- Concatenation: Disabled
- RTS timeouts: Disabled
- Timing Source: X21 Port

As applied to the SMX3/40	
Switch 1	‘01000100’ (8 down to 1)
Switch 2	‘01001001’ (8 down to 1)
Switch 3	‘01001010’ (8 down to 1)
Switch 4	‘00000000’ (8 down to 1)
Switch 5	‘00000001’ (8 down to 1)
Switch 6	‘00000000’ (8 down to 1)

The OPV Series II Radio Unit simply provides a transparent data path and therefore only requires the connected port to be correctly configured. The Radio Unit operates as a DCE and as such requires the SMX3/40 to operate as a DTE. Additionally timing must always be sourced from the Radio Unit.